

GN 816 | Indexing plungers

Safety stop, steel



- 1
- 2
- 3
- 4
- 5
- 6
- 7
- 8
- 9
- 10
- 11
- 12
- 13
- 14
- 15
- 16
- 17
- 18

1 THREADED BODY

Zinc-plated steel.

2 PLUNGER

AISI 303 stainless steel.

3 LOCKING NUT

Zinc-plated steel.

4 KNOB AND SLEEVE

High-resilience polyamide based (PA) technopolymer, black colour, matte finish.

5 STANDARD EXECUTIONS

- **GN 816-A:** with knob, without locking nut.
 - **GN 816-AK:** with knob, with locking nut.
 - **GN 816-B:** with sleeve for operation with key, without locking nut.
 - **GN 816-BK:** with sleeve for operation with key, with locking nut.
- Key in high-resilience polyamide based (PA) technopolymer, black colour, matte finish. Zinc-plated steel hub.
Available as accessory sold separately (see table).

6 FEATURES AND APPLICATIONS

GN 816 indexing plungers are protruding in the rest position. By pulling the plunger inside the body and turning the knob by 90°, the plunger reaches the retracted safety position by means of the pin sliding inside a slit. The plunger returns into the original protruding position by pulling once again the knob, making it turn by 90° and releasing it. For GN 816-B and GN 816-BK the above operations may be carried out only by means of a key (to be ordered separately). Supplied with the technopolymer sleeve not assembled. It can be assembled eventually by a simple pressure.

7 ACCESSORIES ON REQUEST

- GN 609.5: AISI 303 stainless steel distance bushings for the assembly of the indexing plunger on thin sheets (see page 562).
- GN 816-10: key in high-resilience polyamide based (PA) technopolymer, black colour, matte finish. Zinc-plated steel hub. For all versions.

8 SPECIAL EXECUTIONS ON REQUEST

Indexing plungers with red clamping knob (GN 816-AR).

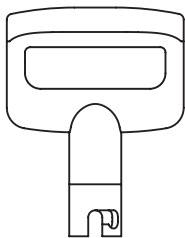
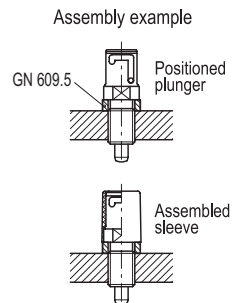
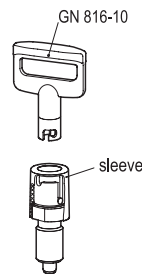

GN 816-10

Code	Description	
GN.39901	GN 816-10	10

Conversion Table 1 mm = 0.039 inch	
d1	
mm	inch
6	0.24
8	0.31
10	0.39

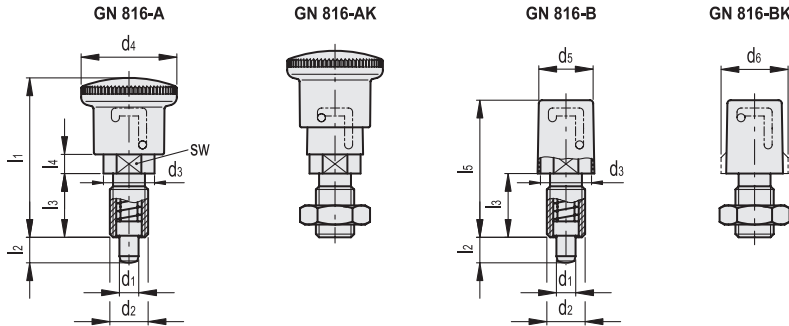

GN 816-A

METRIC

Code	Description	d1 Plunger -0.05 Hole +0.15 +0.07	d2	d3	d4	l1	l2	l3	l4	sw	Spring preload [N]	Spring max load [N]	⚖
GN.39911	GN 816-6-M12x1.5-A	6	M12x1.5	16	28	50	8	20	6	14	13	28	50
GN.39917	GN 816-8-M12X1.5-A	8	M12x1.5	16	28	50	8	20	6	14	13	28	55
GN.39921	GN 816-8-M16x1.5-A	8	M16x1.5	18	28	52	10	22	6	16	14	38	58
GN.39927	GN 816-10-M16X1.5-A	10	M16x1.5	18	28	52	10	22	6	16	14	38	64

GN 816-AK

METRIC

Code	Description	d1 Plunger -0.05 Hole +0.15 +0.07	d2	d3	d4	l1	l2	l3	l4	sw	Spring preload [N]	Spring max load [N]	⚖
GN.39912	GN 816-6-M12x1.5-AK	6	M12x1.5	16	28	50	8	20	6	14	13	28	53
GN.39918	GN 816-8-M12X1.5-AK	8	M12x1.5	16	28	50	8	20	6	14	13	28	58
GN.39922	GN 816-8-M16x1.5-AK	8	M16x1.5	18	28	52	10	22	6	16	14	38	64
GN.39928	GN 816-10-M16X1.5-AK	10	M16x1.5	18	28	52	10	22	6	16	14	38	68

GN 816-B

METRIC

Code	Description	d1 Plunger -0.05 Hole +0.15 +0.07	d2	d3	d5	d6	l2	l3	l4	l5	sw	Spring preload [N]	Spring max load [N]	⚖
GN.39915	GN 816-6-M12x1.5-B	6	M12x1.5	16	17	-	8	20	6	43	14	13	28	30
GN.39919	GN 816-8-M12X1.5-B	8	M12x1.5	16	17	-	8	20	6	43	14	13	28	35
GN.39925	GN 816-8-M16x1.5-B	8	M16x1.5	18	17	20	10	22	6	48	16	14	38	38
GN.39929	GN 816-10-M16X1.5-B	10	M16x1.5	18	17	20	10	22	6	48	16	14	38	44

GN 816-BK

METRIC

Code	Description	d1 Plunger -0.05 Hole +0.15 +0.07	d2	d3	d5	d6	l2	l3	l4	l5	sw	Spring preload [N]	Spring max load [N]	⚖
GN.39916	GN 816-6-M12x1.5-BK	6	M12x1.5	16	17	-	8	20	6	43	14	13	28	33
GN.39920	GN 816-8-M12X1.5-BK	8	M12x1.5	16	17	-	8	20	6	43	14	13	28	38
GN.39926	GN 816-8-M16x1.5-BK	8	M16x1.5	18	17	20	10	22	6	48	16	14	38	42
GN.39930	GN 816-10-M16X1.5-BK	10	M16x1.5	18	17	20	10	22	6	48	16	14	38	48



Indexing and positioning elements